

Fibre optic Patch panel 1U 24 ports SC Duplex steel black up to 48 fibers



24 port Fibre optic sliding Patch panel

This innovative, robust 1U sliding patch panel. This panel has been designed to accept up to 24 fibres housed within a 1U space.

With the ability to use a full array of adaptor types offering a flexible solution to the end user, enabling them to incorporate a multi functional panel which allow easy access during installation or re-work with no disturbance of the existing cable or fibres.

In the addition to the array of adaptors the panel also offers multiple cable entry solutions, up to 4 standard cable entry points for, loose tube, tight buffer, pre terminated and steel tape armoured cable.

Each panel has integrated strength member tie positions also with the additional removable plate at the rear of the panel allows the installation of steel tape armoured cable.

Features

- Up to 48 fibres in 1U
- Multiple Adaptor options available
- 24 Adaptor positions
- Individually labeled ports
- 45° open working angle
- Accepts loose tube, distribution and pre terminated cables
- RoHS, REACH SvHC and UL rated
- Fits standard 19"



Applications

- Data centers, premise installations, telecommunication networks
- Ethernet, Fibre Channel, ATM, LAN, MAN and WAN
- Data communication
- Indoor applications

Specifications

ELEMENT	CHARACTERISTIC
U Size	1U (44.4mm)
Width	482mm
Depth	205mm
Net weight	2.5 kg
Packaged weight	3 kg
Packaged dimensions	530mm W X 55mm H x 260mm D
IP rating	IP20
Suitable for Adaptor type	SC Duplex
Number of ports	24
Cable Entry 20mm	2
Cable entry 25mm	2
Mounting Adjustment range	50mm
Material	Cold- rolled steel
Material thickness	1.2mm
Material coating	Powder coating
Colour	RAL 9004
Operating temperature	-40°C to +50°C
Designed in accordance with	TIA/EIA 568.C, ISO/IEC 11801, EN50173, IEC60304, IEC61754,EN297-1
Compliant to	RoHS, Reach/SVHC

Technical Drawing

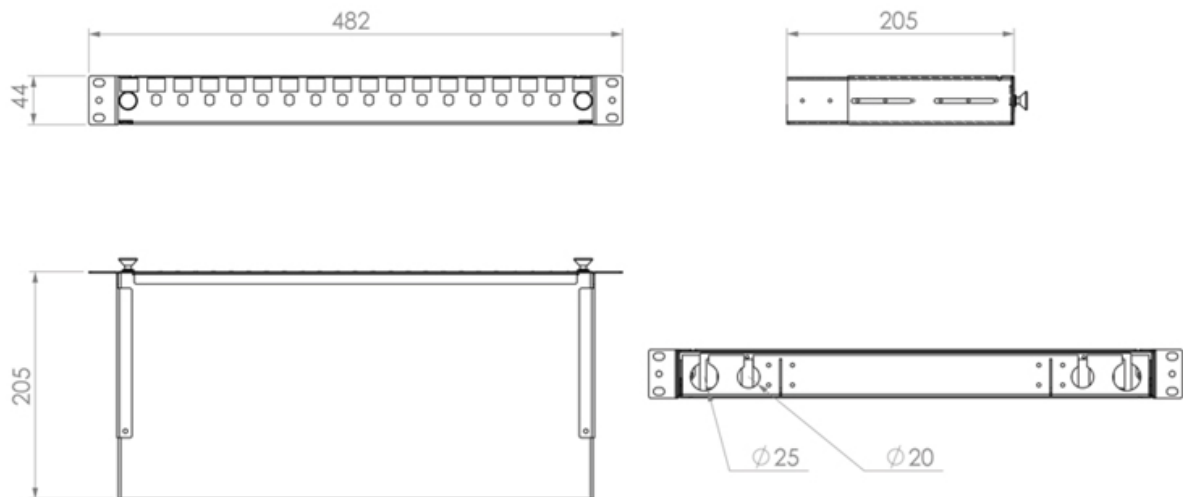

Ordering Information

Product number	Part Name
S09SCM12	Fibre patch panel 12p SC DX MM incl. adapters
S09SCM12FE62	Fibre patch panel 12p SC DX MM OM1 incl. adapters, pigtails, splice cassette, 45mm splice protector
S09SCM12FE50	Fibre patch panel 12p SC DX MM OM2 incl. adapters, pigtails, splice cassette, 45mm splice protector
S09SCM12FEOM3	Fibre patch panel 12p SC DX MM OM3 incl. adapters, pigtails, splice cassette, 45mm splice protector
S09SCM12FEOM4	Fibre patch panel 12p SC DX MM OM4 incl. adapters, pigtails, splice cassette, 45mm splice protector
S09SCM24	Fibre patch panel 24p SC DX MM incl. adapters
S09SCM24FE62	Fibre patch panel 24p SC DX MM OM1 incl. adapters, pigtails, splice cassette, 45mm splice protector
S09SCM24FE50	Fibre patch panel 24p SC DX MM OM2 incl. adapters, pigtails, splice cassette, 45mm splice protector
S09SCM24FEOM3	Fibre patch panel 24p SC DX MM OM3 incl. adapters, pigtails, splice cassette, 45mm splice protector
S09SCM24FEOM4	Fibre patch panel 24p SC DX MM OM4 incl. adapters, pigtails, splice cassette, 45mm splice protector
S09SCS12	Fibre patch panel 12p SC DX SM incl. adapters
S09SCS12FE	Fibre patch panel 12p SC DX SM incl. adapters, pigtails, splice cassette, 45mm splice protector
S09SCS24	Fibre patch panel 24p SC DX SM incl. adapters
S09SCS24FE	Fibre patch panel 24p SC DX SM incl. adapters, pigtails, splice cassette, 45mm splice protector